

## **Students' Perception and Acceptance of Web-based Technologies: A multi-group PLS analysis in Romania and Spain**

### **Abstract**

The study is conducted on 558 under-graduate students in Romania and Spain to examine potential differences in perception and acceptance items towards using web-based technologies. The research model is based on the Internet Attitude Scale (IAS) and measures Perceived Enjoyment, Perceived Anxiety, Perceived Usefulness and Computer Self-Efficacy. Results from country-based group comparisons reveal significant differences in all four constructs, while gender does not seem to affect any of them. Multiple-group PLS analysis reveals similarities but also a couple of differences in the relationship paths for the Romanian and Spanish students. Overall, the examined model fits well in the combined-complete population.

**Keywords:** Cultural context; Higher education; Internet use attitude scale; IAS measurement model, IAS PLS analysis; Students' attitudes

**Word count:** 4.439

### **Author names and affiliations**

#### **Balta Nuri (First author)**

University of International Business

Almaty, Abay ave. 8a, Kazakhstan

E-mail address: [baltanuri@gmail.com](mailto:baltanuri@gmail.com)

#### **Măță Liliana**

„Vasile Alecsandri” University of Bacău

Mărășești Street, 157, 600115, Bacău, Romania

E-mail address: [lsacara@yahoo.com](mailto:lsacara@yahoo.com), [liliana.mata@ub.ro](mailto:liliana.mata@ub.ro)

Tel: +40745157852

#### **Hervás Gómez Carlos**

University of Seville

4 San Fernando Str. Sevilla 41004, Sevilla, Spain

E-mail address: [carloshervas@gmail.com](mailto:carloshervas@gmail.com)

#### **Tzafilkou Katerina**

University of Macedonia, Greece

Egnatia 156, 54636, Thessaloniki, Greece

E-mail address: katerinatza@gmail.com

### **Corresponding author**

#### **Tzafilkou Katerina**

Postal address: Egnatia 156, 54636, Thessaloniki, Greece

E-mail address: katerinatza@gmail

### **1. Introduction**

Research demonstrates that learning is most effective when students are involved in the process (Huang et al., 2017; McLoughlin & Nakano, 2010) and training strategies that engage students in learning via web-based activities stimulate the critical thinking and increase the level of awareness and responsibility on their part (Tzafilkou et al., 2015). To this end, a new direction of research in higher education is to investigate students' attitudes and perceptions towards the use of modern web-based learning technologies such as Twitter (Lackovic et al., 2017), educational video games (Martí-Parreño et al., 2018) and mobile learning (Al-Emran et al., 2016). Investigating students' perception and acceptance towards the use of web-based technologies is essential for the integration of new technologies in the educational process. Also, appropriate attitudes towards the Internet use are a prerequisite for successful web-based instruction (Wu & Tsai, 2006) and for integrating web resources in the classroom (Lundgren & Nantz, 2016). Although the interest in studying attitudes towards the Internet and the use of information and communication technologies (ICT) has increased exponentially, Morse et al. (2011) observed that research on attitudes towards the Internet and web-based interaction is an emerging field. Recently, Nasser (2019) outlined that more research are needed to further explore the nature of usage-context factors and to capture the relationships between different motivation factors of students in adopting e-learning strategies.

Studies based on the attitudes of university students towards the use of the Internet have aimed at either capturing the influence of different factors such as age, ethnicity, etc., or establishing the relationship between these attitudes and different components. Referring to the factors which influence the attitudes towards the use and acceptance of web-based technologies, different aspects have been investigated: age (Rosenthal & Spiegelman, 1996; Spacey et al., 2003), gender (Luan et al., 2008; Mohammad & Alkaraki, 2008; Tsai et al., 2001), ethnicity (Abedalaziz et al., 2013), field of studies (Mohammad & Alkaraki, 2008). Another field of studies aims at identifying the relation between motives and the attitudes and behaviors towards Internet advertising (Celebi, 2015); the use of web-based - Moodle blended learning (Ifinedo et al., 2018; Nasser, 2019), the correlation between computer anxiety, attitudes towards the Internet (Cazacu et al., 2016) and self-efficacy (Durnell & Haag, 2002; Peng et al., 2006; Sam et al., 2005; Tuncer, 2012; Wu & Tsai, 2006). Many studies focus on students' continuance intentions to use e-learning system (Lin & Wang 2012) and instructors' continuous use of e-learning system (Islam 2012; Sharma et al. 2017). Others study the continuous use of web-based learning management systems (LMS) (Lwoga & Komba 2015), continuous use of MOOCs (Zhou 2016), continuous use of webcasts in undergraduate courses (Lust et al., 2012), continuous use of blogs for learning purposes (Ifinedo, 2018), and continuous use of information system (IS) (Terzis et al., 2013). Recently,

studies also include the examination of factors affecting students' adoption of Virtual Learning Platforms (Jena, 2016). The main studies to determine students' attitudes towards the use of Web have also been conducted in primary education (Doğar et al., 2014; Touloupis & Athanasiades, 2018), secondary school (Nikolopoulou, 2017) and high school (Chou et al., 2010; Eduljee & Kumar, 2017).

To this end, this study contributes towards a cross-cultural analysis regarding students' perception and acceptance of web-based technologies as well as the use of Internet. The study was conducted in two different countries, which can provide relevant information for international studies. Another advantage of this study is that it allows establishing comparability with many studies conducted in different cultural environments. Examining students' attitudes towards the use of web-based technologies is useful in obtaining information about computer skills and helping to improve the abilities in using information sources on the Internet. In this way, opportunities are initiated and integrated to prepare students for "university e-learning environments" (Parkes et al., 2015).

The main objective of this study is to investigate university students' perception and acceptance towards web-based technologies, the role of gender and also the relationships between the constructs of Perceived Enjoyment, Perceived Anxiety, Perceived Usefulness and Computer Self-Efficacy for both countries.

#### *The context of studying students' perception and acceptance of web-based technologies in Romania and Spain*

In Romania there are few studies based on investigating the attitudes of students towards the use of the web-based technologies. Cazacu et al. (2016) examined the relationships between computer anxiety and attitudes towards the computer and the Internet of Romanian high-school and university students. Another two studies (Durnell et al., 2000; Durnell & Haag, 2002) were also conducted with Romanian students from the specializations of physics, law, medicine and sociology. The authors identified statistically significant differences between students depending on gender, since the male students had more experience in using the Internet and the attitudes towards the Internet were more favorable to males than to women. Maican and Cocoradă (2017) published another important study in which they investigated Romanian university students' attitudes towards the use of computers, Internet and smartphones in relation with the field of studies, age, gender and academic performance.

Among the studies carried out in Spain, Goig et al. (2015) aimed at determining the attitudes of teachers of early childhood and primary education towards the Internet and its use, their technological knowledge and their attitudes towards new technologies, since without positive results in these aspects it would be very difficult for them to implement this valuable resource in the classroom. These authors concluded that a good predisposition to the use of the Internet in the classroom requires a change of attitude, methodology and evaluation, taking into account the new role of the teacher, who must go beyond the set of tools and teach to learn and generate knowledge. They consider the Internet as a very positive element for the professional tasks of teachers.

In this sense, Hervás et al. (2016) focused their study on determining the barriers that hinder the curricular integration of Information and Communication Technologies in the classroom, analysing the competences and attitudes of students of the Degree in Early Childhood Education (first, third and fourth year) about technological innovations. The participants of this study were 336 students

of the Faculty of Educational Sciences at the University of Seville (Spain). They concluded that the participants showed a positive attitude when overcoming technophobia or avoiding the addictive and compulsive use of technology.

Ramírez et al. (2012) studied the attitudes and beliefs of secondary education teachers towards the use of the Internet in the classroom. They presented the results obtained using a questionnaire (n=1,721) that comprised different dimensions, generating data regarding the attitudes of the teachers towards the use of the specific Internet applications, or the lack of it, in the teaching tasks for which these were designed, and with the specific training. There was a relationship between the attitudes of the teachers and the use of these resources in the classroom, as well as the role that the age and gender of the teachers plays in their attitudes. Rial et al. (2014) focused on determining the Internet and social networks habits of adolescents, delving into their attitudes, perceptions and beliefs. The results showed that adolescents agree to a great extent that “people their age” make a bad use of the Internet, in general. Aranda et al. (2018) achieved an overview of use, knowledge and perceptions from a biennial survey representative of the Spanish population (16–65+) between 2011 and 2013.

This study starts from the discovery of the remarkable development of technology at international level, especially in the field of internet, on the one hand, and the need to continue studying attitudes towards Internet use in different European countries (Romania and Spain), on the other hand.

The remainder of this paper is organized as follows: Section 2 outlines the research objectives and section 3 describes the research methodology. Section 4 presents the experimental results. Section 5 discusses the findings and current limitations. Finally, section 6 summarizes the conclusions and expresses thoughts for future work.

## **2. Research Model and Hypotheses**

This study aims to explore potential differences in web-related perception and acceptance between Romanian and Spanish students. Towards this aim, this study will first examine the research model validity for both country-based populations. The research model is based on the original Internet Attitude Scale (IAS) as proposed by Zhang (20017) and measures Perceived Enjoyment, Perceived Anxiety, Perceived Usefulness and Computer Self-Efficacy.

Hence, the first Research Objective (RO) is the following:

**RO1:** *Examine the IAS validity for the two country-based populations.*

Then, this study will explore potential group differences (gender and country based) in the measured constructs, namely: Perceived Usefulness, Perceived Enjoyment, Computer Self-Efficacy and Computer Anxiety.

**RO2.1:** *Are there any country-based differences in the mean scores of the four constructs?*

**RO2.2:** *Are there any gender-based differences in the mean scores of the four constructs?*

Finally, based on the customized and valid for this populations scale, a structural research model will be examined in terms of differences among the relationship paths of the IAS constructs. The relationships will be examined based on a set of literature-derived hypotheses. The proposed research model (Figure

1), is applied to Romanian and Spain students in order to examine the relationships among the constructs forming their attitude towards the use of Internet. The model will also be examined in terms of the complete students' population (Romania and Spain).

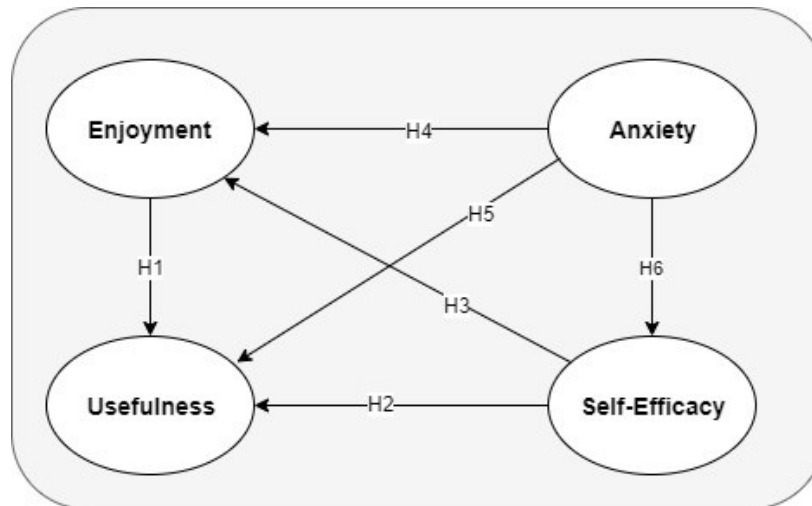

Figure 1 Research Model for IAS Constructs' Correlation Paths

### Perceived Usefulness

The degree to which a user considers that using a specific system will improve his/her job performance is Perceived Usefulness (PU) (Davis, 1989). Several research works have shown the positive effects of perceived usefulness on attitude towards internet use (e.g. Renny et al., 2013) Additionally, Learning Management Systems (LMS) acceptance models highlighted Perceived Usefulness as a very important factor of behavioral intention to use an e-learning system (e.g. Lee, 2008; Ong & Lai, 2006; Van Raaij & Schepers, 2008). Furthermore, Perceived Usefulness is also an essential determinant of Perceived Enjoyment (Terzis & Economides, 2011).

### Perceived Enjoyment

Perceived Enjoyment (PE) is an intrinsic significant belief that is formed from the individual's subjective experience with the system (Moon & Kim, 2001). Moon and Kim described PE as determinant dimensions of perceived playfulness, along with concentration and curiosity. These dimensions are very essential for user's acceptance of computer-based systems. Research results (e.g. Mujiyati & Did, 2008) have shown that there is positive influence between perceived enjoyment and perceived usefulness towards internet usage. Previous studies also showed that PE is one of the most important determinants to use a Computer Based Assessment (Terzis & Economides, 2011).

### Computer Self-Efficacy

Following Bandura's (1997) conceptualization of self-efficacy, Compeau and Higgins (1995) defined computer self-efficacy as "a judgment of one's capability to use a computer [...] Instead of referring to "simple component subskills ...". Computer Self-Efficacy has been showed to positively affect attitude

towards computer usage and technology acceptance variables including perceived usefulness (e.g. Terzis & Economides, 2013; Tzafilkou et al., 2017).

### **Computer Anxiety**

Computer anxiety is defined as stable disposition including cognitive and affective components (Richter et al., 2010). Richter et al. (2000) emphasize that computer attitudes and computer anxiety are not always clearly distinguished. Venkatesh and Bala (2008) argue that the impact of computer anxiety on perceived ease of use and usefulness will decline with increasing experience. Increasing experience will allow users to discover aspects of a system that lead to enjoyment (Venkatesh & Bala, 2008, p. 282). Additionally, several works have pointed out that computer anxiety can negatively influence computer self-efficacy (Achimans Kassim, 2015; Saadé, 2009) although there are some contrary research findings (Alenezi et al., 2010).

Based on the above literature background we conclude on the following correlation hypotheses:

**H1:** *Romania and Spain students' Perceived Enjoyment towards Internet use will have a positive effect on their Perceived Usefulness.*

**H2:** *Romania and Spain students' Computer Self Efficacy will have a significant effect on their Perceived Usefulness.*

**H3:** *Romania and Spain students' Computer Self Efficacy will have a significant effect on their Perceived Enjoyment.*

**H4:** *Romania and Spain students' Computer Anxiety will have a significant effect on their Perceived Enjoyment.*

**H5:** *Romania and Spain students' Computer Anxiety will have a significant effect on their Perceived Usefulness.*

**H6:** *Romania and Spain students' Computer Anxiety will have a significant effect on their Computer Self-Efficacy.*

The structural model is assessed in terms of item loadings, reliability of measures, convergent validity, and discriminant validity as presented in the Results' section. The findings of the current study can be used to discover the nature of university students' attitudes towards Internet use according to country or gender. The students' attitudes towards using the Internet are important in determining the possibility of creating useful programs based on the use of technology in the learning and teaching process from higher education.

## **3. Methods**

### *4.1. Participants*

Students from two countries participated in this study. A total of 558 participants filled in the IAS, 454 students from Romania and 104 students from Spain. Table 1 indicates the demographic features of the samples from both Romania and Spain. As shown in Table 1, the participants from Romania are from diverse groups, such as undergraduate and graduate levels, whereas gender is the only different group for the participants from Spain. For this reason only gender will be examined as a group diversity factor for both countries.

Table 1 Sample Characteristics

Romania N=454		Spain N=104	
Variable	n(%)	Variable	n(%)
<b>Gender</b>		<b>Gender</b>	
Males	97 (21.1)	Males	19 (18.3)
Females	354 (77.1)	Females	85 (81.7)
Missing	8 (1.7)	Missing	0
Missing	8 (1.7)	Missing	0
<b>Age</b>		<b>Age</b>	
19-34	372 (81.0)	19-34	104 (100.0)
35-50	79 (17.2)	35-50	0
Missing	8 (1.7)	Missing	
<b>Major</b>		<b>Major</b>	
Natural sciences	214 (46.6)	Natural sciences	0
Social sciences	237 (51.6)	Social sciences	104 (100.0)
Missing	8 (1.7)	Missing	
<b>Degree</b>		<b>Degree</b>	
Undergraduate students	306 (66.7)	Undergraduate students	104 (100.0)
Graduate students	143 (31.2)	Graduate students	0
Missing	10 (2.2)	Missing	0

#### 4.2. Research Model

The Internet Attitude Scale (IAS) developed and validated by Zhang (2007) was used in this study. IAS consists of 40 items which are rated on a 4-point-likert scale from 1 (Strongly disagree) to 4 (Strongly agree). The items comprise four constructs of Internet use: Perceived enjoyment, usefulness, anxiety, and computer self-efficacy. Since all students from both groups have an intermediate-high English level, the IAS was not translated.

#### 4.3. Data Collection and Procedure

The application of the Internet Attitude Scale was carried out between February and May 2018, with students from two state universities in Romania and Spain. The participants were given the time to complete the scale and were instructed that there were no wrong or fair answers, only personal answers.

#### 4.4. Data Analysis

A Shapiro and Wilk (1965) normal distribution test on the whole sample revealed a non-normal distribution for most of the IAS variables as depicted in Table 2.

Table 2 Shapiro-Wilk's normal distribution test

Variable	Shapiro-Wilk
----------	--------------

	Statistic	df	Sig.
PE	0,97	54	0,16
PU	0,90	54	0,00
AN	0,85	54	0,00
SE	0,85	54	0,00

Since data do not follow a normal distribution throughout all the variables, it is preferred to use non parametric statistical methods for the group comparison and correlational analyses. In particular, Man-Whitney test (Wilcoxon test for independent samples) will be conducted to examine potential differences between the country and gender groups and Partial least-squares (PLS) analysis was used to assess the structural model and conduct the correlational multi-group analysis (Chin, 1998; Falk & Miller, 1992; Lee et al., 2014). PLS was chosen since it is appropriate for non-normal distributed data and the samples for both groups are large enough, since they surpass the minimum limit which is at least 10 times the largest number of independent variables impacting a dependent variable (Chin, 1998). Descriptive statistics was used to demonstrate the mean scores and standard deviations of the measured variables, both for the whole sample size as well for the expertise and gender related groups.

The SmartPLS 3 (Ringle et al., 2015) software was applied to perform factor and reliability analysis of the measurement model while SPSS version 21.0 for Windows (IBM SPSS Statistics) was used for the descriptive statistics, the correlational analyses and the groups' comparisons within the studied population.

#### 4.5. Ethical considerations

This study was achieved and approved in accordance with the operational procedures of "Vasile Alecsandri" University of Bacău from Romania and the University of Seville from Spain. Participants were informed of their right to withdraw from the survey at any point. The participants expressed their consent to complete the questionnaire in the final column, mentioning that they had read all the relevant information and agreed to continue.

## 5. Results

### 5.1. Instrument Validation

The high KMO value of the sampling adequacy test reveals that factor analysis is reliable for the current sample size (Field, 2009) as depicted in Table 3.

Table 3 KMO and Bartlett's Sampling Adequacy Test (N=558)

Kaiser-Meyer-Olkin Measure of Sampling Adequacy.		<b>0.921</b>
Bartlett's Test of Sphericity	Approx. Chi-Square	7230.540
	df	780



Kaiser-Meyer-Olkin Measure of Sampling Adequacy.		<b>0.921</b>
Bartlett's Test of Sphericity	Approx. Chi-Square	7230.540
	df	780
	Sig.	0.000

The reliability of measures was evaluated by composite reliability with its minimum value of 0.70 (Gefen et al., 2000) and Cronbach's alpha with its minimum value of 0.60 (Hair et al., 2006). The discriminant validity was assessed by the square root of AVE and latent variable correlations. Also, factor loadings higher than 0.5 indicate reliability (Hulland, 1999), hence all items showing loadings less than 0.5 were removed from the examined IAS scale. Eventually, the final loadings express values above 0.6. Although Hair et al. (2009) suggest or 0.7 as the ideal lowest value of factor loadings, 0.5 is acceptable when statistical significance and composite or coverage reliability is considered (Arifin & Yusoff, 2016; Hair et al, 2009).

The IAS scale was customized (several items are deleted) during the validity and reliability tests. Only the construct of Self-Efficacy did not need major modification. In particular, for the current study Enjoyment is composed of 4 items (i5, i9, i13, i17), Usefulness is composed of 4 items (i6, i10, i18, i38), Anxiety is composed of 3 items (i7, i11, i39), and Self-Efficacy is composed of 8 items (i4, i8, i12, i16, i20, i24, i28, i40). Finally, only 19 items were validated for the current study, excluding 21 IAS items from the measurement model. The final model, although eliminated, is valid and reliable for both countries populations.

Table 4 displays the selected items' reliabilities (Cronbach's alpha, Composite Reliability) for every country group after removing the items with no valid values according to the cited criteria.

Table 4 Results for the Research Model (RM=Romania, SP= Spain)

Construct Item	Loadings ( $\geq 0.50$ )		Cronbach a ( $\geq 0.60$ )		Composite Reliability ( $\geq 0.70$ )	
	RM	SP	RM	SP	RM	SP
<b>Perceived Enjoyment (PE)</b>			0.64	0.61	0.79	0.77
PE1 (i5)	0.682	0.574				
PE2 (i9)	0.687	0.777				
PE3 (i13)	0.687	0.555				
PE4 (i17)	0.733	0.796				
<b>Perceived Usefulness (PU)</b>			0.61		0.77	0.79
PU1 (i6)	0.770	0.766				
PU2 (i10)	0.669	0.742				
PU3 (i18)	0.626	0.601				
PU4 (i38)	0.636	0.663				
<b>Perceived Anxiety (PA)</b>			0.66		0.82	0.78
PA1 (i7)	0.779	0.682				
PA2 (i11)	0.798	0.763				
PA3 (i39)	0.742	0.760				
<b>Computer Self-Efficacy (CSE)</b>			0.83		0.87	0.86
CSE1 (i4)	0.616	0.596				

CSE2 (i8)	0.660	0.582				
CSE3 (i12)	0.734	0.673				
CSE4 (i16)	0.725	0.724				
CSE5 (i20)	0.632	0.616				
CSE6 (i24)	0.743	0.675				
CSE7 (i28)	0.726	0.684				
CSE8 (i40)	0.622	0.596				

When applied in the complete population the model showed acceptable values of both Cronbach alpha and Composite reliability (>0.70). Factor loadings are depicted in Figure 2.

Table 5 and Table 6 depict the discriminant validity of the models' latent variables for every country. As indicated, the results delivered by the revised measurement model are significant and acceptable, since all the values meet the required standards.

Table 5 Discriminant Validity for the Measurement Model in Romania

	PE	PU	CA	CSE
<b>Construct</b>				
PE	0.774			
PU	0.687	0.697		
CA	0.755	0.666	0.684	
CSE	0.551	0.649	0.521	0.678

Table 6 Discriminant Validity for the Measurement Model in Spain

	PE	PU	CA	CSE
<b>Construct</b>				
PE	0.736			
PU	0.535	0.684		
CA	0.696	0.604	0.654	
CSE	0.545	0.655	0.513	0.696

### 5.2. Descriptive statistics

Table 7 provides descriptive statistics for the measured constructs for the whole population while Table 8 depicts the individual item scores of the IAS for every country separately.

Overall, Table 8 shows that (1) in all items the Spanish participants have more positive attitudes but also increased anxiety, (2) the overall average score of the Spanish group is higher than that of the Romanian group, and (3) while none the average scores of the Romanian group were higher than "4", the Spanish participants showed 14 average scores higher than "4".

Table 7 Descriptive statistics for the whole sample (N=558)

	Minimum	Maximum	Mean	Std. Deviation
PE	1	5	3.48	0.703
PU	2	5	3.68	0.697
PA	1	5	3.17	0.703
CSE	2	5	3.14	0.673

Table 8 Descriptive statistics for every country group

Item	Romania (N=454)		Spain (N=104)	
	Mean	St. Dev	Mean	St. Dev
Perceived Enjoyment				
	<b>3.27</b>	<b>.533</b>	<b>4.44</b>	<b>.623</b>
5	3.40	.667	4.43	.810
9	3.35	.575	4.47	.696
13	2.75	.697	3.81	1.071
17	3.40	.667	4.34	.663
Perceived Usefulness				
	<b>3.45</b>	<b>.525</b>	<b>4.63</b>	<b>.584</b>
6	3.44	.595	4.66	.551
10	3.01	.800	4.63	.671
18	3.28	.596	3.87	.821
38	3.54	.588	4.66	.617
Computer Anxiety				
	<b>2.99</b>	<b>.580</b>	<b>4.02</b>	<b>.682</b>
7	2.87	.701	3.75	.867
11	2.98	.645	4.39	.703
39	3.10	.629	3.80	.829
Computer Self-Efficacy				
	<b>2.93</b>	<b>.529</b>	<b>4.12</b>	<b>.528</b>
4	2.91	.727	4.36	.835
8	2.87	.679	4.27	.779
12	2.78	.697	3.45	.974
16	2.83	.652	4.07	.754
20	2.94	.665	3.89	.709
24	2.89	.666	3.63	.827
28	2.79	.636	3.90	.770
40	3.96	.749	3.96	.749

### 5.3. Group Comparison Analysis

Table 9 presents the Mann-Whitney results for comparing country-based groups. As depicted, all four IAS constructs revealed a significant difference between Romanian and Spanish students.

Table 9 Mann-Whitney Comparison (Grouping Variable: Country)

	PE	PU	CA	CSE
Mann-Whitney U	2174.500	1979.500	3278.000	1697.500
Wilcoxon W	69702.500	69507.500	70806.000	69225.500
Z	-11.144	-11.128	-9.910	-12.086
Asymp. Sig. (2-tailed)	<b>.000</b>	<b>.000</b>	<b>.000</b>	<b>.000</b>

Table 10 presents the Mann-Whitney results for comparing gender-based groups for the whole sample. As depicted, no significant gender differences have been detected between male and female students in the complete population of Romania and Spain. Similarly, no gender differences have been detected within the same country populations neither ( $p > 0.05$ ).

Table 10 Mann-Whitney Comparison (Grouping Variable: Gender)

	PE	PU	CA	CSE
Mann-Whitney U	15353.500	14547.000	14868.000	15531.000
Wilcoxon W	20009.500	19203.000	19524.000	20187.000
Z	-.518	-1.345	-1.055	-.338
Asymp. Sig. (2-tailed)	<b>.604</b>	<b>.179</b>	<b>.291</b>	<b>.735</b>

### 5.4. Structural Model

The structural model was employed to test the hypotheses developed for the correlations in the research model. The test was based on the path coefficients and the  $R^2$  values (Chin & Newsted, 1999) which are used in order to evaluate the significance of the path coefficients and total effects of the hypothesized relationships. Usually, path coefficients greater than 0,1 with t-values greater than level. Both the path coefficients and the  $R^2$  values were evaluated via a PLS algorithm and a bootstrapping procedure (Chin & Newsted, 1999).

Table 11 below presents the t-values and p-values as well as the descendent constructs'  $R^2$  values that were extracted through the bootstrapping procedure for a very country group and for complete population (all) as well. Figure 2 presents the structural model for the complete population, depicting the paths' coefficients, the items' factor loadings and all extracted p-values. As presented there are several significant paths and hypotheses H3 to H6 are confirmed for all studied students' populations.

Table 11 Spain and Romania results in relationships between IAS constructs

	Romania			Spain			All	
	R <sup>2</sup>			R <sup>2</sup>			R <sup>2</sup>	
PE	0.523			0.390			0.685	
PU	0.444			0.482			0.689	
PA								
CSE	0.570			0.434			0.706	
	t-value	p-value		t-value	p-value		t-value	p-value
<b>H1 PE→PU</b>	8.818	0.000	support	5.200	0.626	not support	11.915	0.000
<b>H2 CSE→PU</b>	0.488	0.193	not support	0.488	0.000	support	2.975	0.003
<b>H3 CSE→PE</b>	4.290	0.000	support	4.290	0.000	support	10.704	0.000
<b>H4 PA→PE</b>	8.393	0.000	support	1.841	0.066	support	7.367	0.000
<b>H5 PA→PU</b>	2.741	0.006	support	2.409	0.016	support	3.172	0.002
<b>H6 PA→CSE</b>	34.451	0.000	support	14.062	0.000	support	60.460	0.000

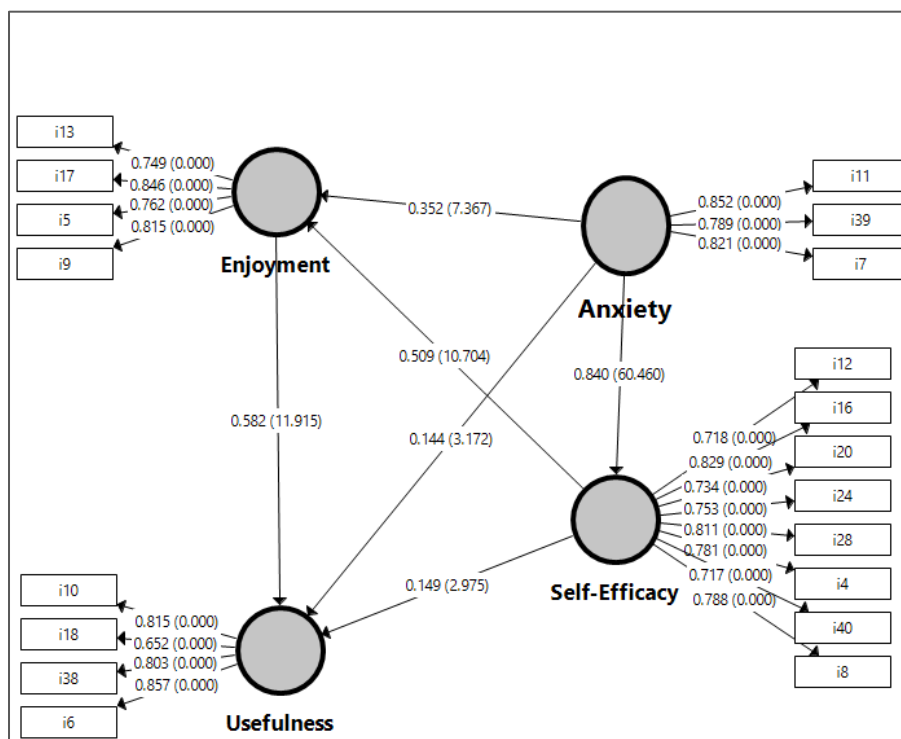

Figure 2 IAS Structural Model results for Spain and Romania (complete population)

## 6. Discussion

### ***Constructs' correlation paths***

As presented in Table 11 and Figure 2, results of the structural model highlighted the confirmation of 4 out of 6 hypotheses. In particular, H1 was confirmed for Romanian students but not for Spanish students since perceived usefulness did not seem to affect perceived enjoyment ( $p\text{-value} > 0.05$ ). However, perceived usefulness affected perceived enjoyment for the complete student population, coming in line with previous literature findings (e.g. Terzis & Economides, 2011).

In addition, H2 was confirmed for Spanish students but not for Romania students ( $p\text{-value} > 0.05$ ). Yet, computer self-efficacy revealed significant effects on perceived usefulness for the complete population. The rest of hypotheses (H3-H6) were confirmed revealing significant path coefficients for every country separated as well as for the complete population of Romanian and Spanish students. The research model for the complete population revealed the highest scores of reliability and consistency and all hypothesized paths showed statistical significance.

### ***Comparing the results on the attitude of students from Romania and Spain***

An important result of present study showed that Spanish students had higher positive attitudes towards the use of the Internet when compared to Romanian students. This means that while Romanian students average attitudes close to agree that of Spanish students is above the agree level. This result could be explained by the attitude of Romanian students to resist to change when presented with something new, following the post-communist mentality after 1989. According to Hervás, López, Real, & Fernández (2016), Spanish students have a more positive attitude when challenged to overcome technophobia or avoiding the addictive and compulsive use of technology. Another explanation could be given by the fact that Romania occupied the last place in Europe in terms of Internet use in 2011 (Eurostat, 2011). Unlike this result, another comparative study revealed similar positive attitudes towards using the Internet in different cultures, like China and Britain (Li & Kirkup, 2007). Comparative studies provide useful data about the attitudes of students from different universities in the European and international scope. This difference in the use of the Internet could also be explained by the training received. According to Ramírez et al. (2012) there is a relationship between Internet training received and the differences in the perception of digital competences of teachers. The results highlight the need to study in more detail the beliefs underlying the adoption or no adoption of these digital resources, how they build up and which elements define them.

### ***The influence of gender on students' perception and acceptance items***

The research results of the present study did not report significant differences regarding *gender*, and that is in line with older studies (Abedalazi et al., 2013; Havelka et al., 2004; Tuncer, 2012; Zhang, 2007). Some studies have shown that attitudes towards the Internet are more favorable to male participants (Durnell & Haag, 2002; Peng et al., 2006; Wu & Tsai, 2006). There are studies that demonstrate that female students have more positive perceptions about the use of Internet than males (Ali, 2014). These results could be explained by the fact that universities have been permanently involved in improving the Internet infrastructure, making these services available to all students. Both male and female students benefit from these services, which highlights the equal access and the opportunity to use the Internet without any gender difference. Also, gender differences have diminished as a result of

the increased opportunities to learn and use the Internet. According to the *specialization*, unlike other studies (e.g. Maican & Cocoradă, 2017), which showed that the students from Engineering and Technological Sciences or Science had positive attitudes compared to the students of Human Development, the results of the present study did not indicate significant differences.

### ***Limitations and future research directions***

There are a number of limitations attached to this study. One of the main milestones is represented by the limited number of participants from Spain. The attitudes of students from Romania and Spain may differ from those of other students who study at other state/private universities in other countries. Therefore, the generalization of results is not possible due to the specific context. The future research may extend the study to integrate comparative analysis between students' attitudes from different universities at international level. It would also be useful to investigate attitudes of students towards the use of the Internet depending on different specializations. An important future research direction will be represented by the investigation of the attitudes of university teachers towards the use of Internet.

### **7. Conclusions**

The main purpose of the study was to examine students' perception and acceptance toward using Internet and web-based technologies in two different countries, Romania and Spain. The study explores potential differences in the measured constructs of Perceived Enjoyment, Perceived Anxiety, Perceived Usefulness and Computer Self-Efficacy as well as in the relationship paths among them. After validity testing an eliminated version of the IAS scale composed of 19 items (out of 40) was applied as the research model. The results indicate that there are significant differences between Spanish and Romanian students both in the constructs' mean values as well as in the relationships between the constructs of the examined model. Additionally, there are no significant gender differences regarding the students' attitudes toward the use of the Internet.

The findings of this study allowed the authors to measure the attitude of the students from the Romanian and Spanish educational systems towards the use of the Internet and examine the relationships among the IAS constructs of Perceived Enjoyment, Perceived Anxiety, Perceived Usefulness and Computer Self-Efficacy. From this perspective, the students from Spain have significantly higher positive Internet use attitudes but also higher perceived anxiety, with respect to Romanian students. Also, most of the assumed correlations between IAS constructs seem to be valid for both country groups. The present study is important, considering that studies on students' attitudes towards the use of the Internet and the investigation of IAS structural correlational models have rarely been done on the Romanian and Spanish populations. A conclusion that emerges from the analysis of recent studies refers to the fact that very few comparative studies have shown the attitudes of students towards the Internet from different cultural backgrounds.

This study has an impact on educational authorities and universities, as it highlights the factors that may affect students' attitudes towards the use of the Internet. Determining students' attitudes towards using the Internet is important, since most students from the two universities in Romania and Spain will become teachers in schools. The results of this study offer university teachers the opportunity to design courses and training programs to develop ICT abilities depending on the age and the level of prior knowledge of students. Future studies can use IAS (or a customized version) to compare populations

from different cultures. The findings of this study will contribute to the successful implementation of eLearning in the university education system.

## References

1. Abedalazi, N., Jamaluddin, S., & Leng, C. H. (2013). Measuring attitudes toward computer and internet usage among postgraduate students in Malaysia. *TOJET: The Turkish Online Journal of Educational Technology*, 12(2), 200-216.
2. Abedalaziz, D.N. (2013). Measuring Attitudes toward Computer and Internet Usage among Postgraduate Students in Malaysia, *Turkish Online Journal of Educational Technology - TOJET*, v12 n2 p200-216 Apr 2013.
3. Al Mahmud, A. (2011). Students' Attitudes towards Internet: A study on Private Universities of Bangladesh. *European Journal of Business and Management*, 3(6), 9-19.
4. Al-Emran, M., Elsherif, H. M., & Shaalan, K. (2016). Investigating attitudes towards the use of mobile learning in higher education. *Computers in Human Behavior*, 56, 93-102.
5. Ali, Z. S. (2014). Pakistani Students' Perceptions about Use of the Internet in their Academic Activities. *E-Learning and Digital Media*, 11(3), 222-230.
6. Aranda, D., Sánchez-Navarro, J., & Mohammadi, L. (2018). An overview of use, knowledge and perceptions of the Internet in Spain. *Data in Brief*, 19, 1498-1503.
7. Arifin, W.A. & Yusoff, S.B. (2016). Confirmatory Factor Analysis of the Universiti Sains Malaysia Emotional Quotient Inventory Among Medical Students in Malaysia. *SAGE Open*. Volume: 6 issue: 2
8. Cai, Z., Fan, X., & Du, J. (2017). Gender and attitudes toward technology use: A meta-analysis. *Computers & Education*, 105, 1-13.
9. Cazacu, A.-M., Cocoradă, E., & Maican, C. I. (2016). Computer anxiety and attitudes towards the computer and the internet with Romanian high-school and university students. *Computers in Human Behavior*, 55, 258-267.
10. Celebi, S. I. (2015). How do motives affect attitudes and behaviors toward internet advertising and Facebook advertising?. *Computers in Human Behavior*, 51, 312–324.
11. Chin, W. W. (1998). The partial least squares approach to structural equation modeling. In G. A. Marcoulides (Ed.), *Modern business research methods* (pp. 295–336). Mahwah, NJ: Lawrence Erlbaum Associates.
12. Chin, W. W., & Newsted, P. R. (1999). Structural equation modeling analysis with small samples using partial least squares. In R. H. Hoyle (Ed.), *Statistical Strategies for Small Sample Research* (pp. 307–341). California, United States: Sage Publications.
13. Coffin, R. J., & MacIntyre, P. D. (1999). Motivational influences on computer-related affective states. *Computers in Human Behavior*, 15(5), 549-569.
14. Compeau, D. R., & Higgins, C. A. (1995). Computer self-efficacy: Development of a Measure and Initial Test. *MIS Quarterly*, 19(2), 189-211.
15. Doğar, Ç, Kaplan, M., & Gürses, A. (2014). Analysis of the factors that influence the attitudes of elementary students for the internet. *Procedia - Social and Behavioral Sciences*, 122, 453-456.



16. Durndell, A., & Haag, Z. (2002). Computer self-efficacy, computer anxiety, attitudes towards the internet and reported experience with the internet, by gender, in an East European sample. *Computers in Human Behavior*, 18, 521-535.
17. Eduljee, N.B., & Kumar, S.S. (2017). Exploring Attitudes Towards the Internet: A Study of Indian College Students. *International Research Journal of Multidisciplinary Studies*, 3(1), 1-12.
18. Field, A. (2009). *Discovering Statistics Using SPSS (3rd Edition)*. London: SAGE Publication.
19. Goig, R.M., Santoveña, S., & Quintanal, J. (2015). Opinions, attitudes and beliefs in the teachers of the 2nd cycle of early childhood education and first cycle of primary education before the use of internet. [Opiniones, actitudes y creencias en el profesorado del 2º ciclo de educación infantil y primer ciclo de educación primaria ante el uso de internet]. En J. J. Maquilón, Mª P. García, Mª L. Belmonte (eds.), *Educational innovation in formal education [Innovación educativa en la enseñanza formal]* (pp. 405-418). Murcia, España: Editum University of Murcia.
20. Hair, J.F., Black, W.C., Babin, B.J., Anderson, R.E., Tatham, R.L., 2009. *Multivariate data analysis. (7th, Ed.) (Vol. 7)*. Pearson Prentice Hall Upper Saddle River, NJ.
21. Hair, J.F., Hult, G.T.M., Ringle, C.M., Sarsted, M. (2014). *A primer on partial least squares structural equation modeling (PLS-SEM)* Sage, Thousand Oaks
22. Hervás, C., López, E., Real, S., & Fernández, E. (2016). Technophobia: skills, attitudes and training of students of the Degree in Primary Education. [Tecnofobia: competencias, actitudes y formación del alumnado del Grado en Educación]. *International Journal of Educational Research and Innovation (IJERI)*, 6, 83-94.
23. Huang, Y., Chang, D-F. & Wu, B. (2017). Mobile Game-Based Learning with a Mobile App: Motivational Effects and Learning Performance. *Journal of Advanced Computational Intelligence and Intelligent Informatics*. 21. 963-970.
24. Hulland, J. 1999. Use of partial least squares (PLS) in strategic management research: a review of four recent studies, *Strategic Management Journal*, 20(2): 195-204.
25. Ifinedo, P. (2018). Determinants of Students' Continuation Intention to Use Blogs to Learn: An Empirical Investigation." *Behaviour & Information Technology* 37 (4): 381–392.
26. Ifinedo, P., J. Pyke, and A. Anwar. (2018). Business Undergraduates' Perceived Use Outcomes of Moodle in a Blended Learning Environment: The Roles of Usability Factors and External Support. *Telematics and Informatics* 35 (1): 93–102.
27. Instituto Nacional de Estadística (2017). Survey on Equipment and Use of Information and Communication Technologies. [Encuesta sobre Equipamiento y Uso de Tecnologías de Información y Comunicación]. Retrieved from [http://www.ine.es/jaxi/Datos.htm?path=/t25/p450/base\\_2011/a2017/I0/&file=01004.px](http://www.ine.es/jaxi/Datos.htm?path=/t25/p450/base_2011/a2017/I0/&file=01004.px).
28. Institutul National de Statistică [National Institute of Statistics] (2016). Accesul populației la tehnologia informațiilor și comunicațiilor în anul 2016 [People's access to technology of information and communication in 2016]. Retrieved from [http://www.insse.ro/cms/sites/default/files/com\\_presa/com\\_pdf/tic\\_r2016.pdf](http://www.insse.ro/cms/sites/default/files/com_presa/com_pdf/tic_r2016.pdf).
29. Islam, A. (2012). The Role of Perceived System Quality As Educators' Motivation to Continue E-learning System Use" *Transactions on Human-Computer Interaction* 4 (1): 25–43.

30. Israel, O. (2013). Attitude of undergraduates towards educational usage of the Internet: A case of library schools in Delta and Edo States of Nigeria. *International Journal of Science and Technology Educational Research*, 4(4), 57-62, DOI: 10.5897/IJSTER2013.0209.
31. Jena, R.K. (2016) Investigating the interrelation between attitudes, learning readiness, and learning styles under virtual learning environment: a study among Indian students, *Behaviour & Information Technology*, 35:11, 946-957.
32. Lackovic, N., Kerry, R., Lowe, R., & Lowe, T. (2017). Being knowledge, power and profession subordinates: Students' perceptions of Twitter for learning. *The Internet and Higher Education*, 33, 41-48, <https://doi.org/10.1016/j.iheduc.2016.12.002>.
33. Lee, C., Lee, H., Lee, J. & Park, J. (2014) A multiple group analysis of the training transfer model: exploring the differences between high and low performers in a Korean insurance company, *The International Journal of Human Resource Management*, 25:20, 2837-2857
34. Li, N., & Kirkup, G. (2007). Gender and cultural differences in Internet use: A study of China and the UK. *Computers and Education*, 48(12), 301-317.
35. Lin, W.-S, and C.-H. Wang. 2012. "Antecedences to Continued Intentions of Adopting E-learning System in Blended Learning Instruction: A Contingency Framework Based on Models of Information System Success and Task-technology Fit." *Computers & Education* 58 (1): 88–99.
36. Luan, W. S., Fung, N. S., & Atan, H. (2008). Gender differences in the usage and attitudes toward the Internet among student teachers in a public Malaysian university. *American Journal of Applied Sciences*, 5(6), 689-697.
37. Lundgren, T. D., & Nantz, K. S. (2016). Student Attitudes toward Internet Courses: A Longitudinal Study. *Journal of Computer Information Systems*, 43(3), 61-66.
38. Lust, G., J. Elen, and G. Clarebout. (2012). Adopting Webcasts Over Time: The Influence of Perceptions and Attitudes." *Journal of Computing in Higher Education* 24 (1): 40–57.
39. Lwoga, E. T., and M. Komba. (2015). Antecedents of Continued Usage Intentions of Web-based Learning Management System in Tanzania." *Education + Training* 57 (7): 738–756.
40. Maican, C. I., & Cocoradă, E. (2017). Computers, Internet and Smartphone Attitudes Among Romanian University Students. *European Journal of Multidisciplinary Studies*, 5(1), 85-92.
41. Martí-Parreño, J., Galbis-Córdova, A., Miquel-Romero, M. J. (2018). Students' attitude towards the use of educational video games to develop competencies. *Computers in Human Behavior*, 81, 366-377, <https://doi.org/10.1016/j.chb.2017.12.017>.
42. McLoughlin and K. Nakano, (2010). A Perspective on the Experiential Learning of Computer Architecture," 2010 IEEE/ACM Int'l Conference on Green Computing and Communications & Int'l Conference on Cyber, Physical and Social Computing, Hangzhou, 2010, pp. 868-872.
43. Mohammed, J., & Al-Karki, J. (2008). Integrating Internet into traditional education: A practical study of university students' usage and attitudes. *The International Arab Journal of Information Technology*, 5(3), 45-63.
44. Moon, J., & Kim, Y. (2001). Extending the TAM for a world-wide-web context. *Information and Management*, 38(4), 217–230.
45. Mujiyati, M. & Did, A. (2008). The Role of Perceived Enjoyment on Motivating the Internet Use. *Universitas Muhammadiyah Surakarta*, Volume 12 No 1 Juni 2008.

46. Nasser M. S. (2019) Motivation factors and barriers to the continuous use of blended learning approach using Moodle: students' perceptions and individual differences, *Behaviour & Information Technology*.
47. Nikolopoulou K. (2017). Adolescents' Internet Attitudes: A Study in an Experimental Greek Secondary School. In: Tatnall A., Webb M. (eds.), *Tomorrow's Learning: Involving Everyone. Learning with and about Technologies and Computing. WCCE 2017. IFIP Advances in Information and Communication Technology*, vol. 515. Springer, Cham.
48. Nur`ain Achim, Arraqib Al Kassim, Computer Usage: The Impact of Computer Anxiety and Computer Self-efficacy. (2015). *Procedia - Social and Behavioral Sciences*, Volume 172, Pages 701-708
49. Parkes, M., Stein, S., Reading, C. (2015). Student preparedness for university e-learning environments. *The Internet and Higher Education*, 25, 1-10, <https://doi.org/10.1016/j.iheduc.2014.10.002>.
50. Peng, H. P., Tsai, C.-C., & Wu, Y.-T. (2006). University students' self-efficacy and their attitudes toward the Internet: the role of students' perceptions of the Internet. *Educational Studies*, 32(1), 73-86.
51. Ramírez, E., Cañedo, I., & Clemente, M. (2012). Attitudes and Beliefs of Secondary Teachers about Internet Use in their Classrooms. [Las actitudes y creencias de los profesores de secundaria sobre el uso de Internet en sus clases]. *Comunicar*, 40, 147-155. <https://doi.org/10.3916/C40-2012-03-06>.
52. Renny, Suryo Guritno, Hotniar Siringoringo, Perceived Usefulness, Ease of Use, and Attitude Towards Online Shopping Usefulness Towards Online Airlines Ticket Purchase. (2013). *Procedia - Social and Behavioral Sciences*, Volume 81,, Pages 212-216
53. Rial, A., Gómez, P., Braña, T., & Varela, J. (2014). Attitudes, perceptions and Internet and social networks use among Galician teens (Spain). [Actitudes y percepciones y uso de Internet y las redes sociales entre los adolescentes de la comunidad gallega (España)]. *Anales de Psicología*, 30(2), 642-655. <http://dx.doi.org/10.6018/analesps.30.2.159111>.
54. Ringle, Christian M., Wende, Sven, & Becker, Jan-Michael. (2015). *SmartPLS 3*. Bönningstedt: SmartPLS. Retrieved from <http://www.smartpls.com>
55. Rodgers, S., & Chen, Q. (2002). Post-adoption attitudes to advertising on the internet. *Journal of Advertising Research*, 42(5), 95-104, DOI: 10.2501/JAR-42-5-95-104.
56. Rosenberg, M. J., & Hovland, C. I. (1960). Cognitive, affective, and behavioral components of attitudes. In C. I. Hovland & M. J. Rosenberg (Eds.), *Attitude Organization and Change: An Analysis of Consistency among Attitude Components* (pp. 1- 14). New Haven: Yale University Press.
57. Saadé, D. K. (2009) Computer anxiety in e-learning: the ffect of computer self-efficacy *Journal of Information Technology Education*, 8 (2009), pp. 177-191
58. Sam, H. K., Othman, A. E. A., & Nordin, Z. S. (2005). Computer Self-Efficacy, Computer Anxiety, and Attitudes toward the Internet: A Study among Undergraduates in Unimas. *Educational Technology & Society*, 8(4), 205-219.

59. Sepahpanah, M., Movahedi, R., Farani, A. Y. (2015). The Study of Students' Attitudes towards the Use of Internet in Education (Case Study: Kermanshah Azad University). *Magazine of E-learning Distribution in Academy*, 6(3), 40-50.
60. Shapiro, S. S.; Wilk, M. B. (1965). An analysis of variance test for normality (complete samples). *Biometrika*. 52 (3-4): 591-611.
61. Smith, B., Caputi, P., & Rawstone, L. (2000). Differentiating computer experience and attitude towards computers: An empirical investigation. *Computers in Human Behavior*, 16, 59-81.
62. Spacey, R., Goulding, A., & Murray, I. (2003). ICT and change in UK public libraries: Does training matter?. *Library Management*, 24(1-2), 61-69.
63. SPSS Inc. Released 2008. *SPSS Statistics for Windows, Version 17.0*. Chicago: SPSS Inc.
64. Terzis, V., & Economides, A. A. (2011). The acceptance and use of computer based assessment. *Computers & Education*, 56(4), 1032-1044.
65. Terzis, V., C. N. Moridis, and A. A. Economides. 2013. "Continuance Acceptance of Computer Based Assessment Through the Integration of User's Expectations and Perceptions." *Computers & Education* 62: 50-61.
66. Terzis, V., Moridis, C. N., Economides, A. A., & Rebolledo-Mendez, G. (2013). Computer Based Assessment Acceptance: A Cross-cultural Study in Greece and Mexico. *Educational Technology & Society*, 16 (3), 411-424.
67. Touloupis, T., & Athanasiades, C. (2018). Principals' Attitudes towards Risky Internet Use of Primary School Students: The Role of Occupational Factors. *Education and Information Technologies*, 23(1), 497-516.
68. Tsai, C.-C., Lin, S. S. J., & Tsai, M.-J. (2001). Developing an Internet Attitude Scale for high school students. *Computers & Education*, 37, 41-51.
69. Tuncer, M. (2012). Investigation of effects of computer anxiety and internet attitudes on computer self-efficacy. *International Journal of Social Science*, 5(4), 205-222.
70. Tzafilkou, K., Chouliara, A., Protogeros, N., Karagiannidis, C. & Koumpis, A. (2015). Engaging end-users in creating data-intensive mobile applications: A creative 'e-learning-by-doing' approach. *International Conference on Interactive Mobile Communication Technologies and Learning (IMCL)*, IEEE
71. Tzafilkou, K., Protogeros, N., Karagiannidis, C., Koumpis, A. (2016). Gender-based behavioral analysis for end-user development and the 'RULES' attributes. *Education and Information Technologies*, 22 (4), 1853-1894.
72. Venkatesh, V., Morris, M. G., Davis, G. B., & Davis, F. D. (2003). User acceptance of information technology: Toward a unified view. *MIS Quarterly*, 27(3), 425-478.
73. Wu, Y.-T., & Tsai, C.-C. (2006). University Students' Internet Attitudes and Internet Self-Efficacy: A Study at Three Universities in Taiwan. *CyberPsychology & Behavior*, 9(4), 441-450.
74. Zhang, Y. (2007). Development and validation of an internet use attitude scale. *Computers & Education*, 49, 243-253.
75. Zhou, M. (2016). Chinese University Students' Acceptance of MOOCs: A Self-determination Perspective. *Computers & Education* 92: 194-203.
76. Havelka, D., Beasley, F. and Broome, T. (2004), A Study of Computer Anxiety Among Business Students, *American Journal of Business*, Vol. 19 No. 1, pp. 63-71.